



Operating Manual

Stands

Hydra-Tech International
#110, 5842 – 86 Avenue SE
Calgary AB Canada T2C 4L7 (403) 720-7740
www.hydratech.net

Table of Contents

Safety Information	1
Overview & Maintenance	2
Operating Instructions	3
Service Centres	5
Warranty	6

Important Safety Information

To ensure the safe use of this equipment it is the responsibility of the owner and operator that any individual operating this equipment or working in the vicinity of this equipment is deemed to be competent, defined by the region's Safety Codes and Regulations, an example is as follows:

Competent: in relation to a person, means adequately qualified, suitably trained and with sufficient experience to safely perform work without supervision or with only a minimal degree of supervision.

In order for the equipment to perform as designed and safely proper maintenance must be performed periodically.

Improper operation, maintenance, lubrication and repair of this equipment may result in serious injury or death.

Hydra-Tech stands are specially designed pieces of equipment and as such should NOT be modified in any way.

Hydra-Tech International is not capable of foreseeing every possible circumstance that may involve a potential hazard. As such, the warnings within this document and labeled on the equipment are not all-inclusive. It is the owner and operator's responsibility to first ensure that any use of this equipment not specifically recommended by Hydra-Tech International, be it operation, maintenance, lubrication or repairs, be deemed safe for the equipment

operator, all persons present, and prevent damages to the equipment.

Information, images, and specifications contained within this document are based on information available at the time it was written or last revised. The contents of this document may change over time and the latest version of this document should be obtained by the owner and/or operator prior to use of the equipment.

For further information or suggestions regarding the safe operation, maintenance and repair of the Stand please contact Hydra-Tech International using the following contact information:

#110, 5842 – 86th Avenue SE

Calgary, Alberta, Canada T2C 4L7

Telephone (403) – 720 – 7740

Fax (403) – 720 – 7758

Website: <http://www.hydra-tech.net/contactus.html>

Safety is everybody's business!

- Wear proper personal protective equipment when service equipment is being used.
- Always confirm the weight of your load and use equipment of sufficient load bearing capacity.
- Always visually inspect equipment for damage prior to use.

Overview

Hydra-Tech International Stands are offered in a variety heights and capacities, with extensions and saddles to meet your specific needs. Stands are constructed of aluminum to offer a light weight stand option, but do not compromise on strength or load bearing capacity.



Daily Maintenance Checklist

Visually inspect for the following:

- Bent or damaged components including struts, handles, and saddles.
- Check for cracked welds.
- Tire pressure and wheel assembly.
- Shackles & lifting slings.
- Overall unit condition.



Do not use a damaged unit!

It is recommended that all stands be load tested at least annually to ensure good condition of the unit, allowing for safe use.

Operating

Prior to using the stand, perform an inspection for damages to ensure equipment is suitable for safe use. Refer to the daily maintenance checklist on page 2 for further information on inspecting a Hydra-Tech stand.

Lifting the Stand:

- Shackles and Lifting Slings are provided for lifting the stand and should be used every time that lifting the stand is necessary.
- Before lifting the stand, the positioning handle should be removed, and the wheels should be placed in the retracted position.
- Straps are attached to the stand to help secure extensions and saddles during transportation of the stand

Stand Set Up:

1. Check to ensure that the ground beneath the stand is capable of fully supporting the load without setting.
2. Ensure that surface that the stand will be placed on is clean, flat, and level.
3. Move the wheels from the retracted position to the lowered position.
4. Unfold and pin the handle.
5. Attach the handle to the mount located between the wheels on the stand base.
6. Smoothly depress the handle until the stand base is clear of the ground and roll the stand into position.
7. After the load is set on the stand and stable, the handle can be removed and the wheels put in the retracted position.



The contact surface of the load and the stand should be parallel and flat, no bolts or protrusions that can point load the stand can be present for safe use!



Ensure that the stand is supported uniformly or under the legs for proper load distribution! Refer to the image below.

Correct Loading

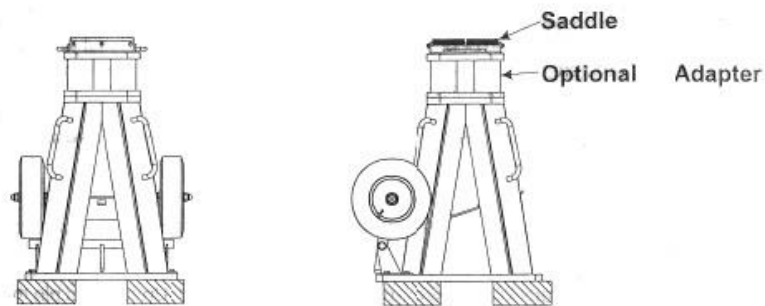

Incorrect Loading

Which will damage the stand and may not support the load.

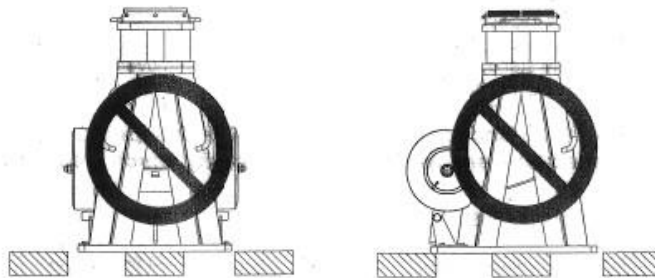

Failure to set up the stand according to the criteria cited in this manual could result in damage to the stand, other equipment, personal injury or death.

Service Centres

Please contact Hydra-Tech International for current information on the closest service center to you. Contact information for Hydra-Tech International follows:

#110, 5842 – 86th Avenue SE, Calgary, Alberta, Canada T2C 4L7
Telephone (403) – 720 – 7740 Fax (403) – 720 – 7758 Website:
www.hydra-tech.net

STANDARD WARRANTY

1. **WARRANTY POLICY.** Subject to those terms and conditions contained herein, Seller warrants that all Seller products conform in all material respects to the description identified in the quotation, proposal or offer made by Seller to Buyer for the sale of its products (collectively, "**Quotation**") and will be free from defects in material and workmanship for two (2) years from the date of shipment to Buyer (except for spare parts which Seller warrants for one (1) year from the date of shipment to Buyer). Products manufactured by manufacturers other than Seller and/or its affiliates ("**Other Manufacturer's Products**") supplied by Seller to Buyer are not warranted by Seller. Other Manufacturer's Products may be warranted separately by their respective manufacturers and Seller shall, to the extent possible, assign to Buyer whatever rights Seller may obtain under any such warranties.

THE FOREGOING REPRESENTS THE SOLE AND EXCLUSIVE WARRANTY GIVEN BY SELLER TO BUYER AND IS IN LIEU OF AND EXCLUDES ALL OTHER WARRANTIES, EXPRESS OR IMPLIED, ARISING BY OPERATION OF LAW (INCLUDING BY STATUTE) OR OTHERWISE, INCLUDING BUT NOT LIMITED TO ANY IMPLIED WARRANTIES OF MERCHANTABILITY OR FITNESS FOR A PARTICULAR PURPOSE.

2. **WARRANTY REMEDIES.** Buyer's sole and exclusive remedy for Seller's breach of the foregoing warranties during the warranty period shall be, at Seller's sole discretion, the repair and/or replacement of any defective products (or component parts thereof) pursuant to the terms of and conditioned upon Buyer's compliance with the procedure identified in Section 5 hereof.
3. **LIMITATION OF DAMAGES. SELLER SHALL HAVE NO LIABILITY TO BUYER OR ANY END USER OF PRODUCTS OR SERVICES WITH RESPECT TO THE SALE OF PRODUCTS OR PROVISION OF SERVICES UNDER THE QUOTATION FOR LOST PROFITS OR FOR SPECIAL, CONSEQUENTIAL, EXEMPLARY, OR INCIDENTAL DAMAGES OF ANY KIND WHETHER ARISING IN CONTRACT, TORT, PRODUCT LIABILITY, STRICT LIABILITY OR OTHERWISE, EVEN IF SELLER WAS ADVISED OF THE POSSIBILITY OF SUCH LOST PROFITS OR DAMAGES. IN NO EVENT SHALL SELLER BE LIABLE TO BUYER FOR ANY DAMAGES WHATSOEVER IN EXCESS OF THE TOTAL PRICE PAID BY BUYER FOR PRODUCTS AND/OR SERVICES REFERENCED IN THE QUOTATION.**
4. **INAPPLICABILITY OF, AND VOIDING OF THE WARRANTY.** This Standard Warranty does not cover defects in Seller products which are not defects in material and workmanship and may be attributed to other causes including but not limited to failure to operate and/or maintain Seller products in accordance with the applicable Seller installation and/or operator's manuals, owner's manuals, maintenance manuals, manufacturer's recommendations, and any other manuals, guidelines or recommendations of Seller concerning the maintenance and operation of Seller products that may be communicated to Buyer from time to time, side-pulling of load, shock loading, excessive jogging, eccentric loading, overloading, accidental occurrence, improper repair, improper handling or storage of products, chemical exposure and/or abnormal operating conditions not identified to and expressly and specifically accepted by Seller in writing prior to Seller's issuance of a Quotation, or any other cause that in Seller's sole discretion is not attributable to defects in material and workmanship. Failure of products to meet published performance specifications due to abnormal operating conditions beyond Seller's knowledge or control shall not be considered defects in either workmanship and/or material.

Modification of Seller products and/or incorporation of Other Manufacturer's Products into Seller products by individuals and/or organizations other than Seller shall void this Standard Warranty.

Buyer's failure to pay in full when due for the products and services provided for in a Quotation shall void this Standard Warranty.

5. **WARRANTY PROCEDURE.** To obtain warranty remedies pursuant to this Standard Warranty, Buyer must strictly adhere to the following procedure. Buyer's failure to comply with the terms of this procedure shall void this Standard Warranty.
- (a) Buyer shall, within seventy-two (72) hours of any claimed non-conformance or defect in Seller products, notify Seller's Warranty Administrator in writing of the alleged non-conformance or defect.
 - (b) Seller shall, within a reasonable time, advise Buyer of its intention to initially accept or deny the warranty claim pursuant to the terms of this Standard Warranty. If Seller elects to initially accept the warranty claim, it shall advise Buyer of its intention to replace, repair, or otherwise further inspect the allegedly nonconforming or defective products (or component parts thereof) ("**Initial Acceptance**").
 - (i) **Replacement of allegedly nonconforming or defective products.** Should Seller provide Initial Acceptance of Buyer's warranty claim and elect to replace the allegedly nonconforming or defective products (or component parts thereof), or should Seller elect to provide Initial Acceptance of Buyer's warranty claim through notification to Buyer that Seller elects to inspect the allegedly nonconforming or defective products (or component parts thereof) and then subsequently elect to replace the allegedly nonconforming or defective products (or component parts thereof), Seller shall within a reasonable time, ship new, comparable, replacement products to Buyer F.C.A. Seller's plant, warehouse or dock, as defined by Incoterms 2010, via the lowest cost method available.
 - (ii) **Repair of allegedly nonconforming or defective products.** Should Seller provide Initial Acceptance of Buyer's warranty claim and elect to repair and/or permit the repair of the allegedly nonconforming or defective products (or component parts thereof) by approved third parties, or should Seller elect to provide Initial Acceptance of Buyer's warranty claim through notification to Buyer that Seller elects to inspect the allegedly nonconforming or defective products (or component parts thereof) and then subsequently elects to repair the allegedly nonconforming or defective products, Seller shall, unless otherwise agreed in writing by the Warranty Administrator, pay only those direct labor costs incurred to effectuate the repair and the cost of Seller replacement products consumed during said repair provided that the costs for all products and/or services are approved in advance in writing by Seller's Warranty Administrator.
 - (iii) **Inspection of allegedly nonconforming or defective products.** Should Seller provide Initial Acceptance of Buyer's warranty claim through notification to Buyer that Seller elects to inspect the allegedly nonconforming or defective products (or component parts thereof) and then subsequently determine that the alleged

nonconformity or defect is not covered under this Standard Warranty, Seller shall bill Buyer, and Buyer shall pay Seller any and all costs associated

- (iv) with the performance of inspection of allegedly nonconforming or defective products.

WAIVER. BUYER HEREBY WAIVES ANY CLAIM THAT THE EXCLUSIONS OR LIMITATIONS IDENTIFIED HEREIN DEPRIVE IT OF AN ADEQUATE REMEDY. BUYER SHALL BE ENTITLED TO NO OTHER REMEDY OTHER THAN THOSE IDENTIFIED IN SECTION 2 HEREOF WITH RESPECT TO THE PROVISION OF PRODUCTS AND/OR SERVICES BY SELLER REGARDLESS OF THE FORM OF CLAIM OR CAUSE OF ACTION, WHETHER BASED IN CONTRACT, TORT INCLUDING NEGLIGENCE, STRICT LIABILITY OR OTHERWISE.