



POWER MOVER

Power Driven Pump and Jack + Stand Mover

- Works with all Mod-U-Lift and Lift Stand jacks.
- Safely and effortlessly move jacks and stands into position.
- Control 2 jacks with optional splitter manifold.
- No need to balance jack when moving around pad.
- Jack stays horizontal to the ground.

PRODUCT DEVELOPMENT

Mod-U-Lift and Stand PowerMover

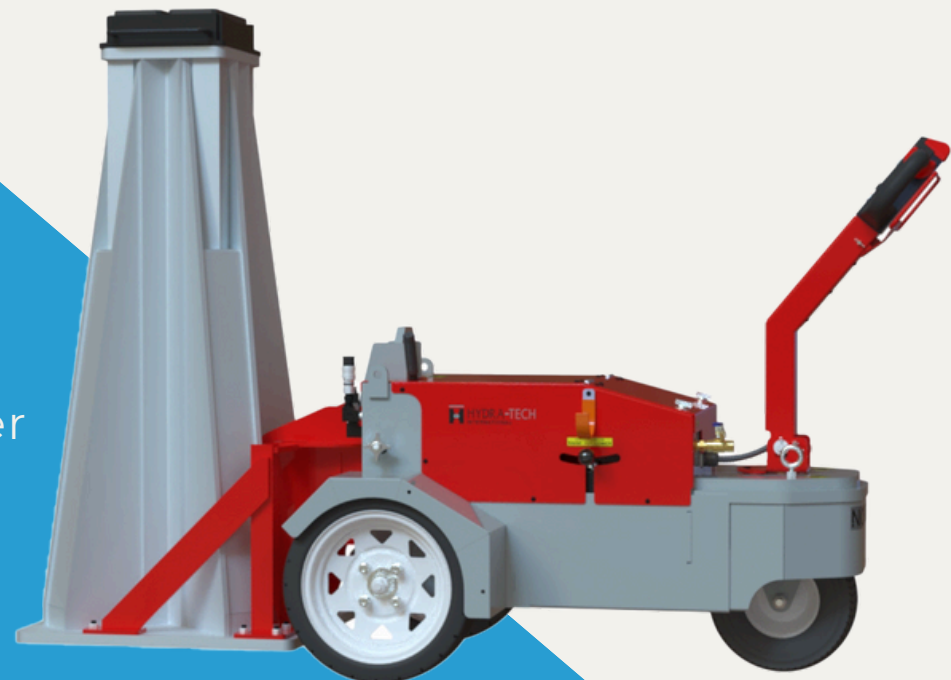

FEATURES

- Driven by a battery powered motor.
- Automatic fast charging system. Plugs into a standard 120v circuit.
- Battery disconnect switch.
- Built-in safety auto reverse button on end of handle.
- On board air driven 10,000 PSI hydraulic pump system.
- Flat free tires (Front 17", Back 13").
- The handle can be left in horizontal position or pinned vertically.
- Deadman safety switch feature.
- Handle rests at lower height for better clearance.
- Can also be used with stands (attachment required).
- Hose hooks for transport and storage.

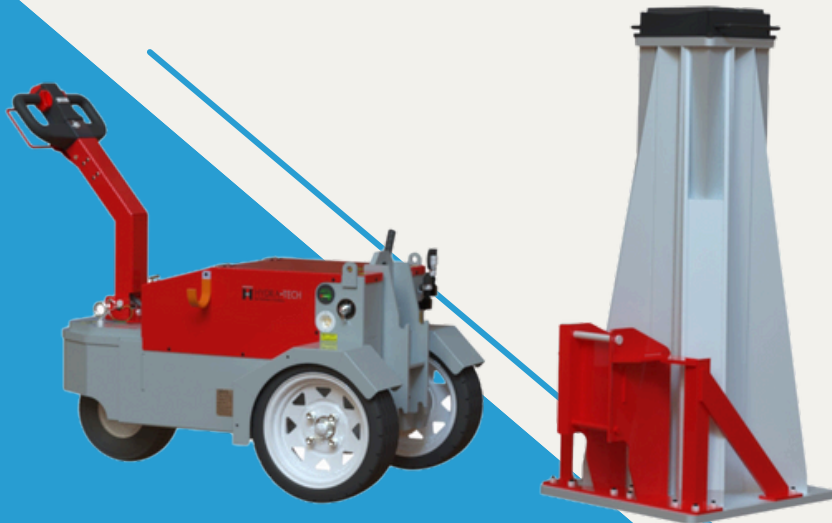
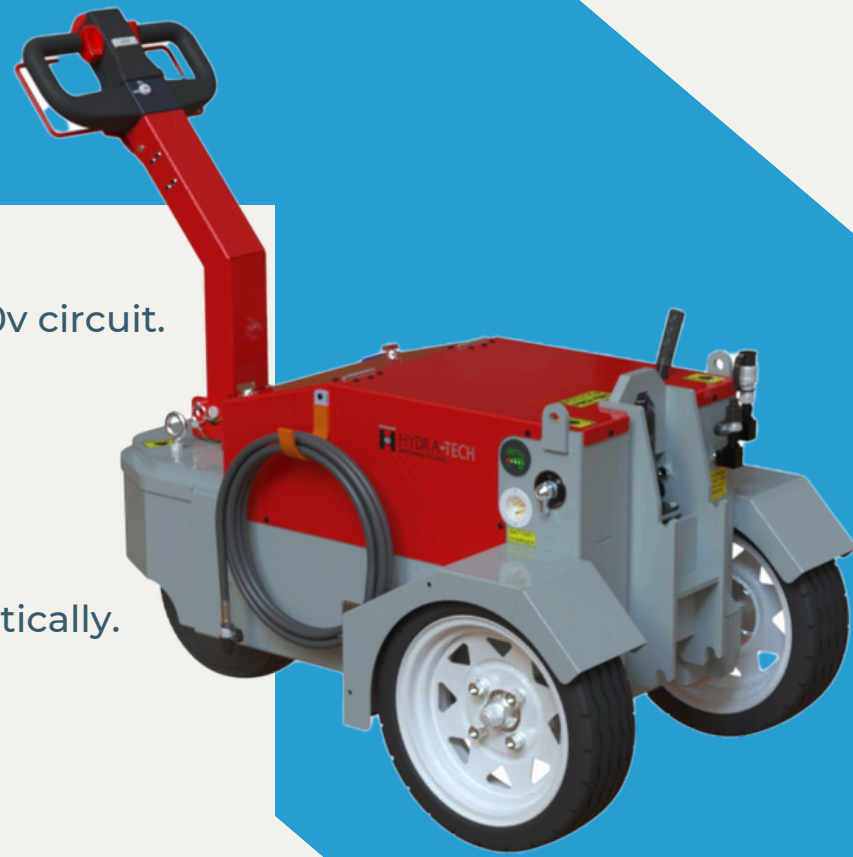

ACCESSORIES & OPTIONS

Stand Frame

Adapter Frame to use with our 120 Ton Mining Stands

Splitter Manifold

Allows the Pump to control 2 jacks.

Remote Air Valve

Allows pump control from a distance up to 12 ft.

Receiver Bracket

One bracket per jack required



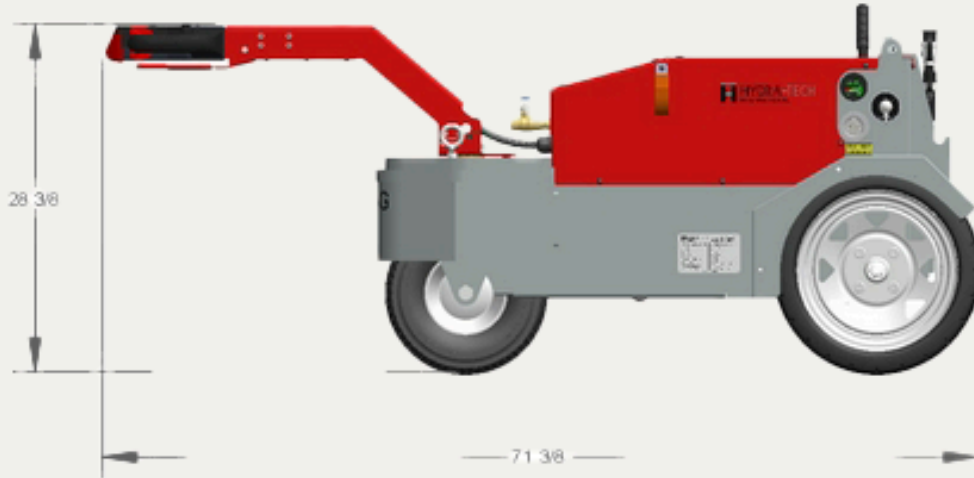

Contact Us

Hydra-Tech International
110 - 5842 86th Ave S.E.
Calgary, Alberta, T2C 4L7

403-720-7740
sales@hydra-tech.net
hydra-tech.net

